

## FORCE SENSOR CL 16U

- high stability and repeatability
- tension and compression mode
- thin profile
- insensitive against out of alignment of force load
- two year warranty and after sales service



The operational force sensor CL 16U has been designed for measuring static and slow-changing forces. Together with ZEPWN instrumentation can find both labor and industrial usage, especially for converting force into electrical signal in industrial automatics and supervising systems.

The conversion of measured load is realized due to a steel spring element with strain gauge full bridge. The bridge is balanced and thermal compensated.

The sensor CL16U in configurations R1, R2 has the strain gauge bridge 350 Ω with sensitivity 1 mV/V or 2 mV/V. For electrical protection IP40 the sensor is equipped with a LUMBERG connector. For electrical protection IP64 the sensor is equipped with a stuffing on connection cable.

### Specifications:

Range	[kN]	1; 2; 5; 10; 20; 50; 100; 200; 500
Configurations		R1, R2
Output signal	[mV/V]	1 - R1, 2 - R2
Non-linearity	[%]	0,5
Nominal supply voltage	[V]	10
Strain gage resistance	[Ω]	350
Input resistance	[Ω]	allu: 410±; steel: 380 ±25
Output resistance	[Ω]	350 ±5
Zero drift	[%/30 min]	≤ 0,03
Return to zero after unloading from nominal load	[%]	≤ 0,03
Operating temperature range	[°C]	-20 ÷ 100
Temperature effect on the sensitivity	[%/10K]	≤ 0,05
Temperature effect on zero	[%/10K]	≤ 0,05
Compensated temperature range	[°C]	0 ÷ 90
Maximal strain	[mm]	0,3
Connectors		Z1 – LUMBERG or O1 – O-ring gland
Protections degree		IP40, IP64
Dimensions		See drawing and table below
Material of spring element		alluminium or steel
Cable length		3 m (standard) or other optional

Designations and wiring for R1 / R2

1 brown	-W <sub>y</sub>
2 pink	0 U <sub>zk</sub>
3 white	0 U <sub>z</sub>
4 yellow	+U <sub>z</sub>
5 grey	+U <sub>zk</sub>
6 green	+W <sub>y</sub>
7 black	shield

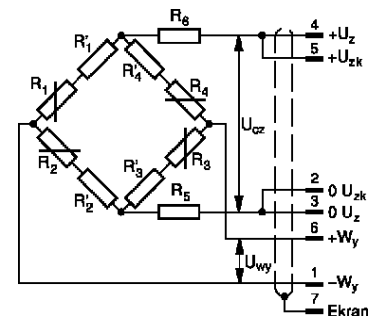

# FORCE SENSOR CL 16U

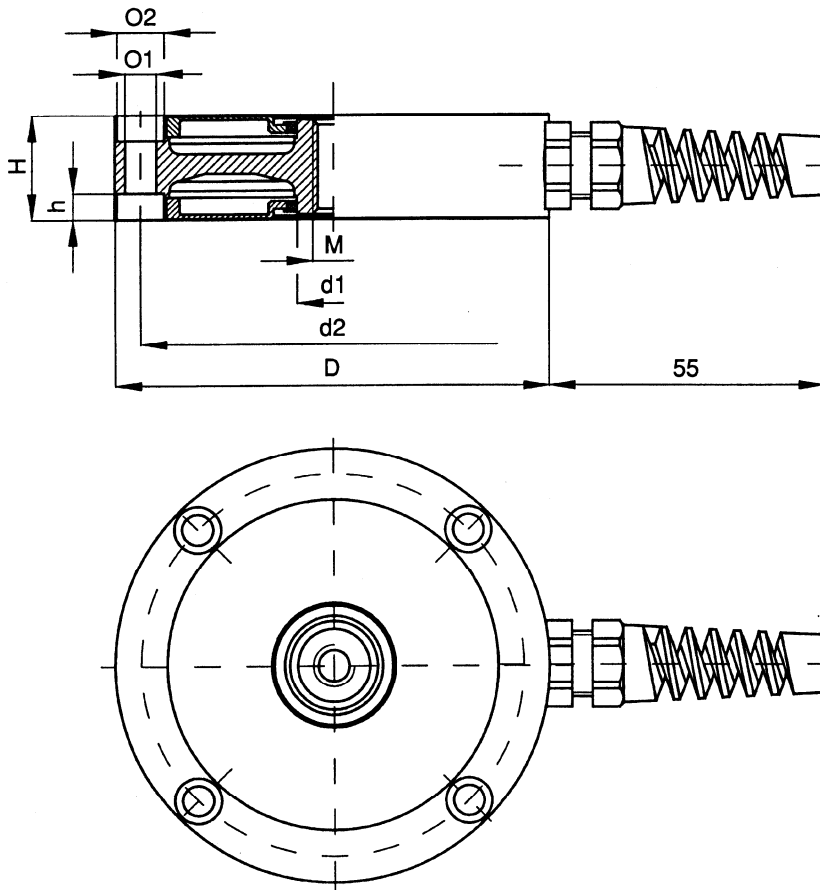

**Quality assurance**  
 Each sensor is detailed examined after manufacturing process. The manufacturer offers 24 month warranty for the sensor and after that time also repair and calibration services.

Range kN	D	H	M	d1	d2	O1	O2	h
mm								
1	85	20	M8	13	74	6,2	9,5	5
2	85	20	M8	13	74	6,2	9,5	5
5	85	20	M8	13	74	6,2	9,5	5
10	125	28	M12	23	110	8,2	12	6
20	128	35	M24x2	40	110	10,2	17	10
50	128	35	M24x2	40	110	10,2	17	10
100	174	40	M36x3	57	145	12,2	19	12
200	180	60	M39x3	65	155	16,5	25	16
500	290	100	M72x4	113	235	20,5	31,4	20

## Options:

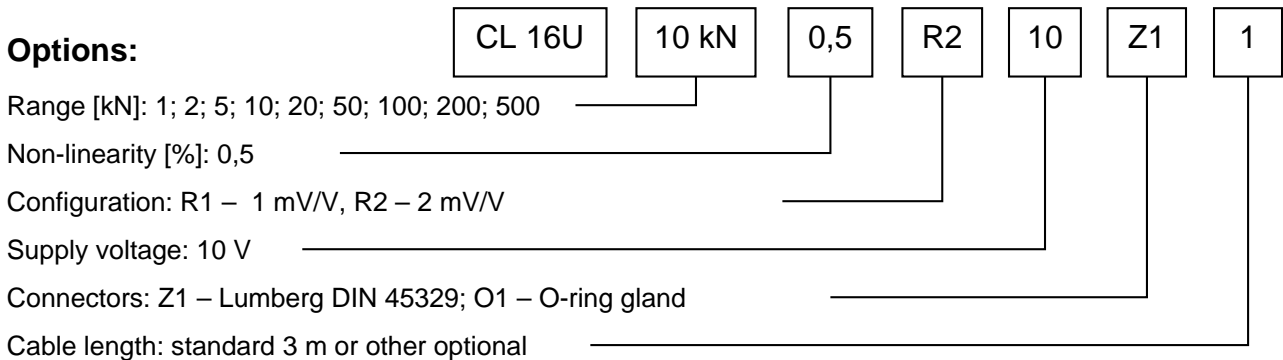

## Example of options for ordering:

CL 16U – 10 kN – 0,5 – R2 – 10- Z1 – 1: sensor with dimensions as in table, range 10 kN; non-linearity 0,5%; sensitivity 2 mV/V; connector Lumberg; cable length 1 m

Manufacturer:

ZEPWN sp. z o.o. sp.k., Poland, 05-270 Marki, ul. Kołtąta 8

tel.: 004822. 781 21 69, 771 24 11, e-mail: [zepwn@zepwn.com.pl](mailto:zepwn@zepwn.com.pl), <http://www.zepwn.com.pl>